

Spyder™ Model 7

VAV CONTROLLER

Honeywell's Spyder™ Model 7 VAV controller is a programmable room controller with integrated actuator and air flow sensor.

As a freely programmable VAV controller with universal inputs and outputs, Spyder™ Model 7 has configuration flexibility to achieve a variety of specific applications. Smart engineering and commissioning tools with Niagara WEBs-N4 workbench and a mobile application for test and balance make installation cost-effective.

Spyder™ Model 7 offers BACnet IP or BACnet MSTP, Sylk™ bus technology, Modbus RTU RS-485, flexible universal input / output (UIO) points and solid-state relays.



FEATURES AND HIGHLIGHTS

COMMUNICATION

- Supports BACnet IP or BACnet MSTP bus for communication.
- BTL-listed, IP VAV: B-BC profile and MSTP VAV: B-AAC profile (BTL certification in process).
- BACnet IP enables faster download, thereby reducing commissioning time, and increased data bandwidth for increased data sharing compared to traditional BACnet MSTP communication.
- BACnet IP variants supports:
 - IPv4 addressing
 - DHCP and Link Local addressing modes
 - Connection speed: 10/100 Mbps
- Modbus client for integration purposes.
- Automatic addressing functionality.
- Sylk™ bus two-wire polarity-insensitive interface connects to Honeywell Sylk™ wall modules without using physical I/O points.
- Integrated BLE (Bluetooth)

ALL-IN-ONE

- Freely programmable in WEBs-N4.
- Compact design for small enclosures and easy to install on round ducts.
- Color-coded, removable terminal blocks to simplify wiring and replacement.
- Real-time clock, a supercapacitor for 24-hour data retention.
- 24 VAC power supply.
- 20 VDC at 75 mA auxiliary supply for field devices.
- Seven universal inputs/outputs usable as analog voltage/current output or as a universal/binary input.
- All UI can be used for pulse input. Maximum frequency 100 Hz, Minimum duty cycle (50 % / 50 %) 5 ms ON / 5 ms OFF.
- Five 24 VAC solid state relay outputs with 1.5 A continuous and 3.5 A in-rush for 100 ms per SSR output.
- Features a non-isolated RS-485 interface for Modbus communication.

ACTUATOR

- Integrated 44 in-lbs (5 Nm) actuator with 90 sec runtime at 60 Hz (108 sec at 50 Hz) with position feedback.

PRESSURE SENSOR

- Field replaceable differential pressure sensor (± 500 Pa; accuracy $\pm 3\%$ of full range).

MOBILE APPLICATION

Mobile app for VAV balancing with easy access to the controller via Bluetooth integrated in the controller.



- Easy pairing without the need to open the ceiling.
- Supports Android and iOS.
- Language support: English, French, Spanish, German, Italian.
- Wireless signal strength indication.
- Password protection
- Supports different types of balancing (min/max, set-point).
- Command individual / group of VAV, e.g. open a group of VAV dampers.
- Provides a report on balancing activities.

PART NUMBERS

PART NUMBER	UNIVERSAL IO	SOLID STATE RELAY (SSR)	TOTAL IO	COMMUNICATION	BLE
WEB-VA75IB24NM	7	5	12	IP	Yes
WEB-VA75I24NM	7	5	12	IP	No
WEB-VA00IB24NM	0	0	0	IP	Yes
WEB-VA75MB24NM	7	5	12	MSTP	Yes
WEB-VA75M24NM	7	5	12	MSTP	No
WEB-VA00MB24NM	0	0	0	MSTP	Yes

REPLACEMENT PART NUMBER	DESCRIPTION
SDPPF500PA	Air flow sensor replacement
ANT-REM	Use the remote antenna if the antenna mounted on the controller does not provide reliable communication due to environmental conditions. The packet contains four antennas.

MOBILE APP



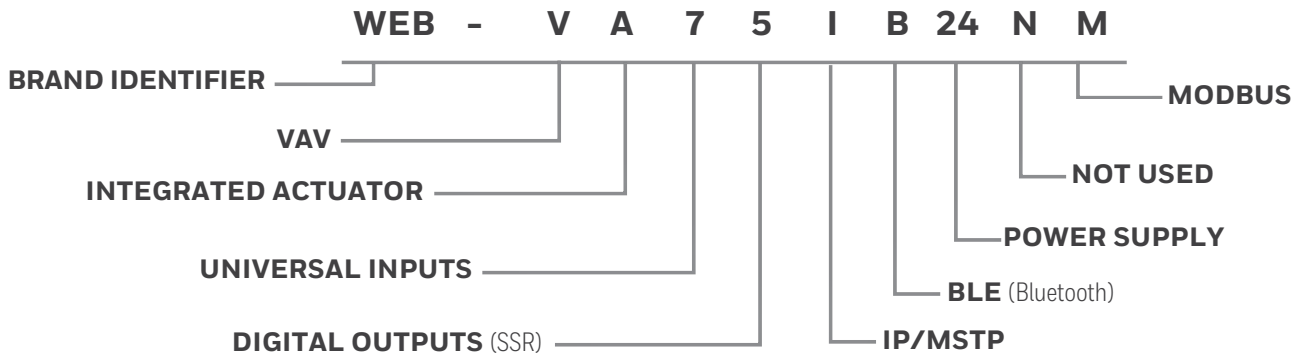

Honeywell Connect Mobile (HCM) app for the VAV balancing can be downloaded from the Google Play Store and Apple App Store. HCM is a mobile application for VAV Balancing. It provides easy access to the Spyder™ Model 7 VAV controller via integrated Bluetooth.

CONTROLLER PART NUMBERS DESCRIPTION

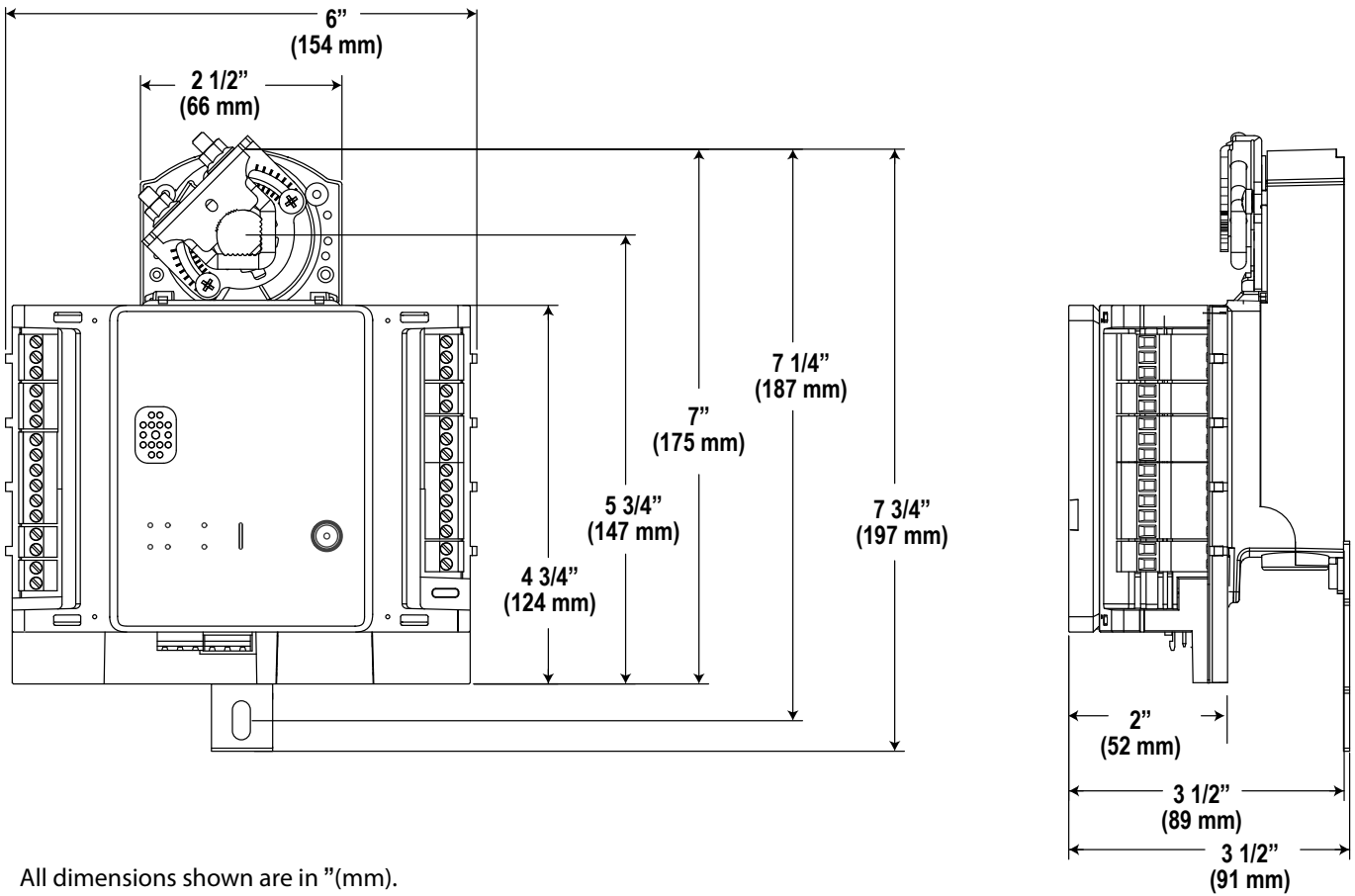

DIMENSIONS



All dimensions shown are in "(mm).

HARDWARE OVERVIEW

TOP VIEW

SIDE VIEW

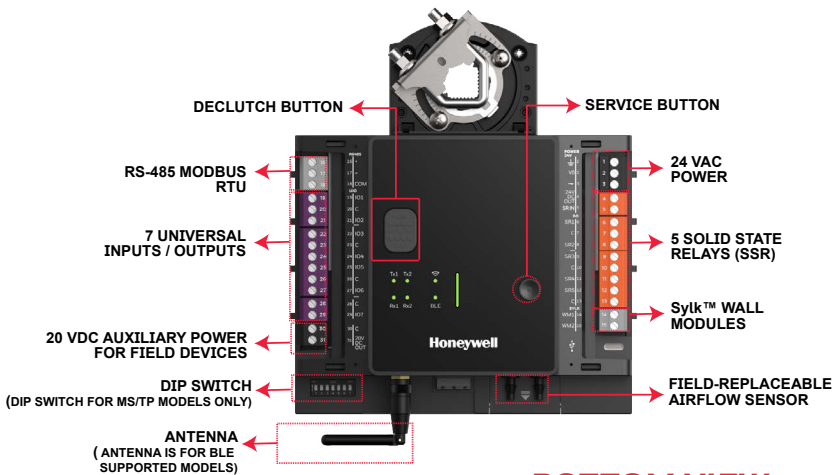

BOTTOM VIEW

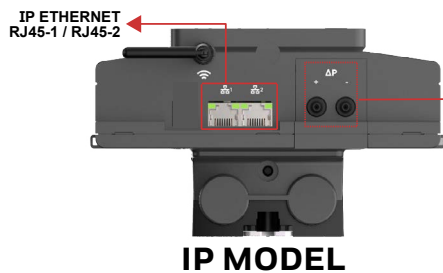

IP MODEL

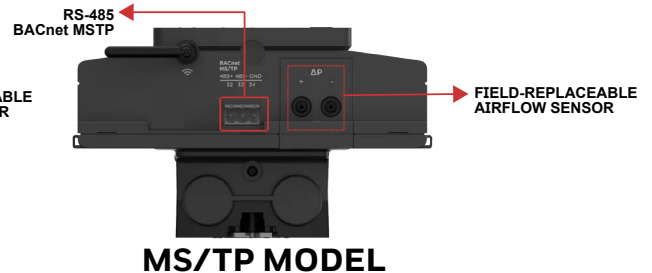

MS/TP MODEL

SYSTEM OVERVIEW - MSTP



*WEBS-N4
Supervisor*

Ethernet switch



WEB-8000



Legend

- Sylk™ bus
- Modbus RTU
- BACnet IP
- BACnet MSTP

Balancing App



BACnet MS/TP



Spyder Model 7 MS/TP



Sylk™ bus



TR120x



TR7x



TR4x



*Sylk™
Actuator*

Wall modules

Modbus RTU



*C7355
IAQ monitor & sensor*



C7355B



*Energy
Meter*



Smart VFD

SYSTEM OVERVIEW - IP

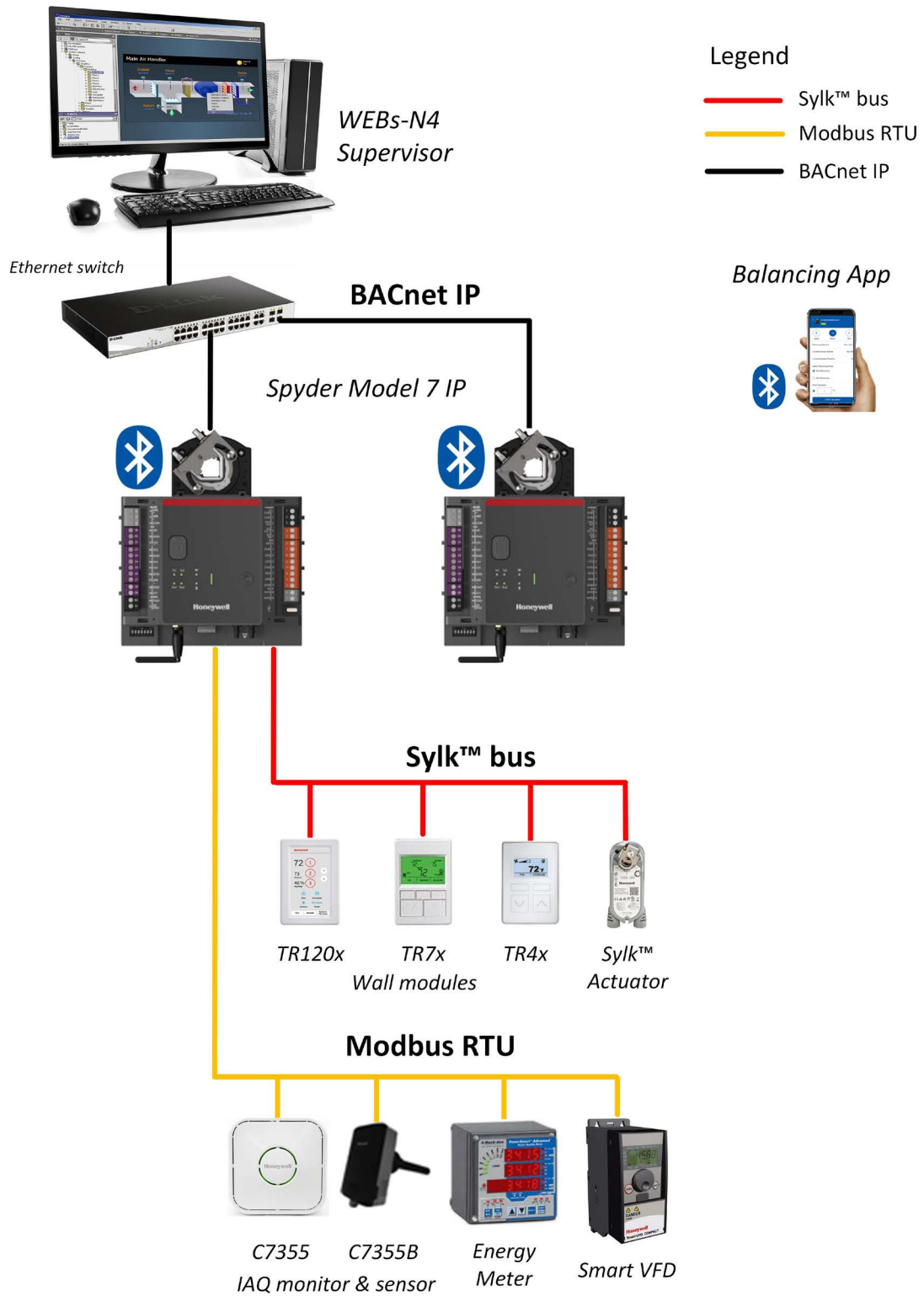

PRODUCT SPECIFICATION

HARDWARE	
PARAMETER	SPECIFICATION
CPU	Crossover processor NXP I.MRT, Cortex M7
Memory capacity	16 MB QSPI Flash, 16 MB SDRAM
Ethernet	2 each RJ-45 ethernet port with integrated fail-safe for daisy chain installation
Real Time Clock	24-hour backup after power failure. In case of power failure, the controller includes a super capacitor to retain the time set with the built-in real time clock for 24 hours. After 24 hours, the time will reset to the factory default time until the user performs a BACnet Time Sync.
Small LEDs	Transmission or reception of BACnet and Modbus communication signal (green)
Large LED	Controller status such as normal operation, firmware download, broken sensor, e.g. green, yellow or red

ELECTRICAL	
PARAMETER	SPECIFICATION
Rated Input Voltage	20 - 30 VAC; class 2 transformer
Nominal Power Consumption (Controller and actuator load, nothing connected to IOs and COM)	<ul style="list-style-type: none"> IP model : 8 VA MSTP model : 6 VA
Full Load Power Consumption (Maximum load including external loads, Sylk™, communication, BLE, Universal IO output, and 20 VDC output excluding the load on the SSRs)	<ul style="list-style-type: none"> IP model : 30 VA MSTP model : 22 VA
Frequency Range	50 to 60 Hz
Auxiliary Output	20 VDC @ 75 mA

OPERATIONAL ENVIRONMENT	
PARAMETER	SPECIFICATION
Storage Temperature	-40 °F to 150 °F (-40 °C to 66 °C)
Operation	32 °F to 122 °F (0 °C to 50 °C)
Humidity	5 % to 95 % RH., non-condensing
Protection	IP20, NEMA -1
Pollution Level	2

INTEGRATED ACTUATOR	
PARAMETER	SPECIFICATION
Torque	44 in-lbs (5 Nm)
Run Time	<ul style="list-style-type: none"> Floating 108 s at 50 Hz Floating 90 s at 60 Hz
Mounting Shaft	<ul style="list-style-type: none"> Round 5/16 – 5/8 in. (8-16 mm) Square 15/64 – 33/64 in. (6-13 mm)
Shaft Length	≥ 1 5/8 in. (41 mm)
Position feedback via integrated potentiometer : <ul style="list-style-type: none"> Periodic synchronization not required Additional diagnostic for e.g. command to change the actuator position does not provide a corresponding sensor reading: actuator stuck or potentiometer damaged 	

DIFFERENTIAL PRESSURE SENSOR	
PARAMETER	SPECIFICATION
Range	±2.0 in. WC (±500 Pa), bi-directional
Accuracy	±3 % of full range
Field replaceable differential pressure sensor.	

SYLK™ SUPPORTED DEVICES	
Sylk™ wall modules	TR40, TR40-H, TR40-CO2, TR40-H-CO2, TR42, TR42-H, TR42-CO2, TR42-H-CO2, TR71, TR71-H, TR75, TR75-H, TR120 (TR75-E), and TR120-H TR75-HE (emulation mode only)
Sylk™ sensors	C7400S Sylk™ sensor
Sylk™ actuator	MS3103, MS3105, MS4103, MS4105, MS7403, MS7405, MS7503, MS7505, MS8103, MS8105 spring return Direct Coupled Actuators (DCA) are used within Heating, Ventilating, and Air-Conditioning (HVAC) systems. They can drive a variety of quarter-turn; final control elements requiring spring return fail-safe operation.

WEIGHT AND DIMENSIONS	
PARAMETER	SPECIFICATION
Dimension (L x W x H)	7 x 6 x 3 1/2 in. (175.2 x 154.3 x 90.2 mm)
Weight	3.3 lbs. (1.5 kg)
Mounting	Fixation with bracket and shaft

SOLID STATE RELAY (SSR)	
SSR switches supply voltage and works with VAC and VDC. VDC switching does not support synchronous motor.	
<ul style="list-style-type: none"> 1.5 A constant; 3.5 A inrush for 0.1 sec. per SSR output Optional jumper between 24 VAC supply and SSR input shared by all SSRs 	

UNIVERSAL IO (CONFIGURABLE AS ANALOG OUTPUT OR UNIVERSAL INPUT)	
PARAMETER	SPECIFICATION
AO	O(2) to 10 VDC direct/reverse with -3 mA to 20 mA or current output with O(4) to 20 mA
UI	<ul style="list-style-type: none"> O(2) to 10 VDC direct/reverse or O(4) to 20 mA input Sensors: 10 K Ohm NTC Type II, 10K-3 NTC, 10K3A1, 20 K ohm NTC, PT100, PT1000, NI1000TK5000, NI1000 Class B DIN43760, PT3000, 100 Ohm to 100 k Ohm resistive (custom characteristic). Hardwired wall modules: set point, fan speed, override Dry contact binary input with direct/reverse All UI can be used for pulse input. Maximum frequency 100 Hz, Minimum duty cycle (50 % / 50 %) 5 ms ON / 5 ms OFF.
The Spyder™ Model 7 VAV controller has a single common terminal for every two Universal IOs, which protects them against 24 VAC mis-wiring and short circuits.	

COMMUNICATION	
PARAMETER	SPECIFICATION
Protocol supported	BACnet IP, BACnet MSTP, Sylk™, Modbus RTU (Modbus client only), and BLE
Ethernet Connection Speed	10/100 Mbps
Internet Protocol version	IPv4
IP Addressing Modes	<ul style="list-style-type: none"> Dynamic : DHCP and Link Local Static
Sylk™ Bus	2-wire, polarity-insensitive
Bluetooth	BLE, optional external antenna

STANDARDS AND APPROVALS

- CE
- BACnet BTL®-Listed; IP VAV model as BACnet Building Controller (B-BC) and MSTP VAV model as BACnet Advanced Application Controller (B-AAC); (BTL certification in process)
- UL916, Energy Management Equipment
- FCC Part 15, Class A
- EN 55022, Class A
- EN 61000-3-2, 61000
- UL2043

CONFORMANCE STATEMENT

FCC NOTICE

This device complies with part 15 of the FCC rules. Operation is subject to the following two conditions:

- This device may not cause harmful interference.
- This device must accept any interference received, including interference that may cause undesired operation.

By using this Honeywell literature, you agree that Honeywell will have no liability for any damages arising out of your use or modification to, the literature. You will defend and indemnify Honeywell, its affiliates and subsidiaries, from and against any liability, cost, or damages, including attorneys' fees, arising out of, or resulting from, any modification to the literature by you.

Honeywell Building Technologies

715 Peachtree St NE
Atlanta, Georgia 30308
customer.honeywell.com
buildings.honeywell.com

@U.S. Registered Trademark
© 2022 Honeywell International Inc.
31-00471 | Rev. 03-22

APPLICABLE TECHNICAL LITERATURE

TITLE	REFERENCE
Spyder Model 7 VAV Installation Instructions	31-00475
Spyder Model 7 VAV Mounting Instructions	31-00473
Spyder Model 5 and Spyder Model 7 System Engineering Guide	31-00282
Spyder Model 5 and Spyder Model 7 Function Blocks User Guide	31-00364
Honeywell VAV Balancing Tools User Guide	31-00472

Honeywell